

# TechneticPlus™

---

## Owner's Manual

**Models:**

SA-TECH PLUS 40 DB  
SA-TECH PLUS 48 DB



**R&M Water Group™**  
Water Conditioning & Purification Systems

A Division of Water Technologies, Inc.

---

28 South 1550 West, Lindon, Utah 84042  
801.785.5557 - Fax 801.785.7823

## Table of Contents:

Item	Page
Introduction.....	2
Equipment Specifications.....	2
Job Specifications Sheet.....	3
Sizing Information.....	3
Glossary of Terms / Maintenance.....	4
Manual Regeneration.....	4
Home Owner Maintenance.....	4 - 6
Manual Bypass Valve.....	6
Pre-Installation Check list.....	6-7
Detailed Installation Instructions.....	7-8
Start-up Rinsing Procedure.....	9-10
Battery Back-Up Feature.....	11
Programming the Control Valve.....	12
Level I Programming.....	12-15
Level II Programming.....	15-16
Level I & II Default Settings.....	17
System Capacity Table.....	18
Flow Diagrams.....	19-20
Pressure Loss Characteristics.....	20
Troubleshooting.....	21-24
Control Valve Diagram.....	25
System / Bypass Diagrams.....	26
Notes.....	27-28

## Introduction:

Your Technetic owner's manual is designed to assist owners and installers with the installation, operation and maintenance of your new Water Conditioning System. Installers and homeowners will appreciate the simplified photo format designed to assist all aspects of operation.

In the event service or plumbing changes are required contact your local authorized Technetic dealer or qualified plumbing professional. If further assistance is required call 800.776.7111.

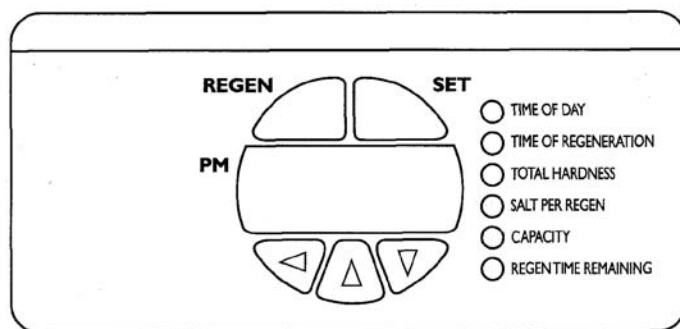

## Equipment Specifications:

Working Pressure.....25 psi to 125 psi  
 Voltage.....102 to 132 vac, 60 Hz  
 Current.....50 mA  
 Transformer.....Wall Mount (indoor use only)  
 Operating Temperature.....34° F to 120° F  
 Humidity.....10% to 100%, Condensing Allowed  
 Service Connections.....3/4", 1", 1 1/4" Copper Tube Adapter  
 Brine Line Connection.....3/8" Tubing  
 Drain Line.....1/2" NPT Male  
 Water Flow.....Accurate over range of .5 to 23 gpm

## Job Specification Sheet:

Home Owner. \_\_\_\_\_

Dealer. \_\_\_\_\_

Date of Installation. \_\_\_\_\_

Installers Name. \_\_\_\_\_

Model #. \_\_\_\_\_ Serial #. \_\_\_\_\_

### Water Characteristics

\_\_\_\_\_ Hardness CaCo3 (check one \_\_\_gpg or \_\_\_ mg/l)

\_\_\_\_\_ Iron (ppm) \_\_\_\_\_ Water pressure.

\_\_\_\_\_ PH \_\_\_ Yes \_\_\_ No Pressure regulator.

\_\_\_\_\_ Other \_\_\_\_\_, \_\_\_\_\_ Other \_\_\_\_\_.

\_\_\_\_\_ Other \_\_\_\_\_, \_\_\_\_\_ Other \_\_\_\_\_.

Water source: \_\_\_\_\_ City, \_\_\_\_\_ Well, \_\_\_\_\_ Other.

Explain other. \_\_\_\_\_.

## Sizing Information:

All Water is treated except: \_\_\_ Front hose Bib \_\_\_ Rear hose Bib \_\_\_ Kitchen  
 \_\_\_ Toilets \_\_\_ Other \_\_\_\_\_.

Sizing formula: On the average 70 gallons of water per person per day is used for Hot and Cold, 50 gallons for Hot water only and 30 gallons for bypassed toilets Hot water only.

Example:

Daily Usage 70\_ (Gallons/Person) X Family size 6 = Total Gallons 420 X  
 Grains per gallon of hardness 20 = Total grains per Day 8400 .

Daily Usage \_\_\_\_\_(Gallons/Person) X Family size \_\_\_\_\_ = Total Gallons \_\_\_\_\_ X  
 Grains per gallon of hardness \_\_\_\_\_ = Total grains per Day \_\_\_\_\_.

## Water Conditioning:

### Glossary of Terms

**Hardness** Is comprised of dissolved calcium and magnesium. As a general rule water is considered to be extremely hard when over 10 gpg of hardness, hard when 6-10 gpg, mildly hard when 3-6 gpg, slightly hard when 1-2 gpg and soft when 0 gpg.

**Measurements:**Your Technetic water system registers hardness in grain per gallon (gpg). Most water analysis reports register hardness in milligrams per liter (mg/l) or parts per million (ppm). To convert either mg/l or ppm to gpg, divide the indicated amount by 17.1.

Example: Water report indicates total hardness of 350/mg/l, divide this number by 17.1 to get the gpg, which would be 20.4.

**Ion Exchange:** Your water conditioning system utilizes ion exchange media, also referred to as resins, to effectively remove hardness ions from the water and replace it with sodium ions. Exhausted resin is cleaned by rinsing the resin beads with salt solution. This causes the resin to exchange hardness ions for the sodium ions, returning the resin to its sodium state.

**Proportionate Brining:** The Technetic System utilizes an advanced microprocessor to control the amount of regenerant proportionate to the amount of exhausted resin. It uses enough salt to bring the system back to 100% capacity. The microprocessor also incorporates a variable reserve feature to enable the system to adjust to patterns of usage, thus maintaining high efficiency.

## Home Owner Maintenance:

**Manual Regeneration:** Occasionally you may find it necessary to initiate a manual regeneration. This is done by pressing the REGEN button on the front of the display. When you press the REGEN button the control performs a full regeneration of the water conditioner immediately.

In the event the system is allowed to run out of salt, it will be necessary to run "Back to Back" regenerations. This can be done easily by pressing the REGEN button one time, waiting at least one minute and pressing the REGEN button again.

Note: The second regeneration will begin immediately after the first is completed.

"Back to Back" regenerations are necessary if full exhaustion occurs due to low regenerate levels or system malfunction. Since the system works on a highly efficient proportionate brining method, the system was not aware of the lack of proper regenerate; thus, a larger portion of the Resin bed was exhausted.

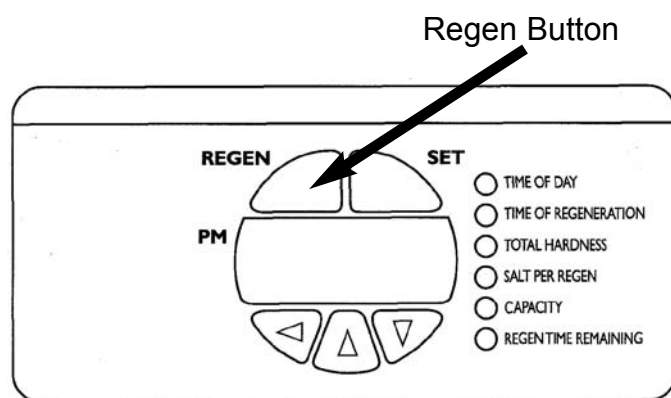

Figure 1

# Home Owner Maintenance:

(Continued)

**Calendar Day Override Feature:** The Technetic System has an optional calendar day override feature. The system comes pre-programmed with this feature turned off. To activate this feature, see Level II Programming instructions beginning on page 15. This feature overrides the registered water volume and initiates a regeneration based on the days selected even if there has been 0 water usage registered. This feature is sometimes used if long absences in the home occur. This insures a clean fresh bed of resin and minimizes the chance of resin fouling.

**Regenerates:** Salt is used to clean the system. Salt pellets are generally cleaner than extra-course rock salt. DO NOT use salt blocks as they may contain vitamin or other undesirable additives. **Add Salt to the brine tank when it drops to within 12" of the bottom.**

**Dry Brine Tank:** Technetic Systems use a dry brine tank. Since the system determines the amount of solution necessary to clean the exhausted resin, water is sent to the brine tank as part of the regeneration sequence in an amount proportionate to the exhausted resin that needs to be cleaned.

Note: While it is a dry brine tank, you will see approximately 1" of water in the bottom of the tank during normal service. This amount of water is necessary for the proper function of the brine air check assembly. If water amount exceeds this level while in normal service position, contact your local service representative or refer to the trouble shooting guide on pages 21-24 of this manual.

**Brine Tank Cleaning:** Insoluble materials will gradually build up in the salt tank depending on the levels found in the salt. As a general rule, inspect the brine tank once a year when the salt level is low. To do this, disconnect the brine-line connection, rinse out any insoluble build-up, reconnect the brine-line, and add one inch of fresh water. Then totally refill the tank with salt.

**Setting Time Clock:** Your clock should indicate the current time of day, provided the clock is set correctly the system will clean at the specified time of regeneration. Refer to page 14 for setting time clock instructions.

**Disinfection of Water Conditioners:** The construction materials of the water conditioning system do not support bacterial growth or contaminate the water supply. However, we recommend that the conditioner be disinfected after installation and before the conditioner can become fouled with organic matter during normal usage or with bacteria from the water supply. Periodic disinfection is recommended for all conditioners. Use the following method of disinfection to clean your system:

### **Sodium Hypochlorite 5.25%**

Sodium Hypochlorite solutions can be used with polystyrene resin, synthetic gel zeolite, greensand, and bentonites and are available under trade names such as Clorox\*. Adjust the dosage if stronger commercial solutions are used.

## Home Owner Maintenance:

(Continued)

The recommended dosage for a 5.25% depends on your system size. Use the following amount depending on your system model:

Model: SA-TECH PLUS 40 DB ..... 1.5 Fluid ounces  
SA-TECH PLUS 48 DB ..... 1.8 Fluid ounces

**Complete the following steps to disinfect the conditioner:** Add the sodium hypochlorite solution to the brine well of the brine tank. Make sure that the brine tank has water in it so the solution is carried into the conditioner. Proceed with manual regeneration. Refer to the Manual Regeneration section.

\*Clorox is a trademark of the Clorox Co.

**Battery Backup feature:** Your Technetic system has a battery backup feature. During a power outage the display will be blank but the microprocessor will continue registering water flow. The system will not initiate regeneration during a power outage; but rather, will wait until full power returns. It is recommended the batter be replaced once a year or after any extended power outage. Battery type should be a standard 9-volt. Detail instructions can be found in the programming section on page 11 of this manual.



Figure 2

## Manual Bypass Valve:

Your Technetic System is equipped with a manual bypass valve. This valve is to be used if you want to stop the flow of water through the equipment but still allow (untreated) water into your home. Some examples of when to use the bypass valve are when a leak occurs in the system or if the homeowners will be gone from the home for an extended period of time. It is recommended that the bypass valve knobs be turned in and out of service once a year to ensure that the o-rings are worked. This allows the bypass valve to turn more freely should it become necessary.

## Pre-Installation Check List:

The following items should be checked and verified prior to the installation of the equipment. Under certain circumstances, as indicated, additional procedures or pieces of equipment may be recommended.

- 1. Water Pressure Verification:** A minimum water pressure of 25 psi is required for normal operation. Maximum water pressure is 125 psi.
- 2. Electrical Requirements:** The system includes a 12 volt transformer to be plugged into a standard 110 volt 60 Hz current. If additional length of cord is required, a 15 foot extension is available. See page 10 for additional details.

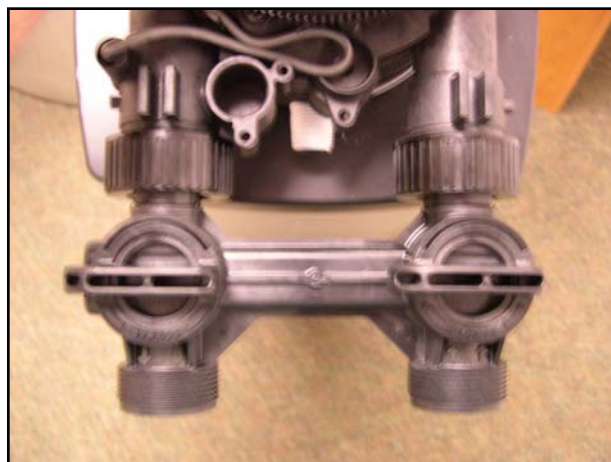

Figure 3

## Pre-Installation Check List:

(Continued)

**3. Drain-Line Connection:** Choose a location close to a drain to put your brine tank. Avoid overhead runs in excess of 25 feet. Drain line must be a minimum of ½" inside diameter. Do not use soft vinyl tubing, 3/8" or smaller tubing or allow tubing to be exposed to freezing. When barb drain fittings are used always use a hose clamp to secure the tubing to the fitting. Do not connect the drain line to the over flow line on the salt storage container. Installation of the drain line should be in accordance with all state and local plumbing codes.

**4. Installation Site:** When choosing the proper locations for the equipment consider the following factors:

- A. Closeness to drain.
- B. Closeness to electrical outlet.
- C. Access to plumbing; it is recommended that both Hot and Cold Water be treated with the exception of outside taps when possible. Kitchen cold is optional. Additional equipment may work better with treated water. Consult you dealer for details and the best option for your application.



Figure 4

**5. Unpacking System:** After removing the system from the box inspect the system for any concealed damage that may have occurred in shipping. If damage occurred, contact your dealer for details. **Do not install if the system has sustained damage.**

## Detailed Installation Instructions:

### General Installation Warnings:

The following general warnings should be observed when installation and or general service maintenance is performed.

1. Plumbing connections should be done in accordance with state and local plumbing codes.
2. Do not use with water that is microbiologically unsafe or of unknown quality without adequate disinfection before or after the system.
3. Drain lines should be ½" minimum for drain line flows up to 7gpm, flows above 7 gpm or runs in excess of 20 feet will require ¾" drain line.

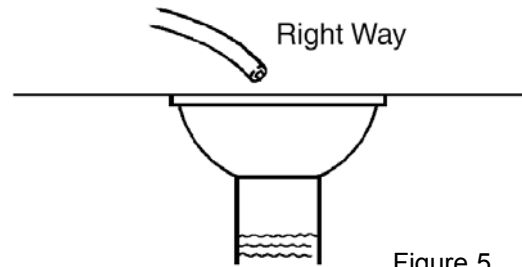

Figure 5

**IMPORTANT:** Never connect drain line directly into a drain, sewer line or trap. Always allow an air gap between the drain line and the wastewater to prevent the possibility of sewage being back-siphoned into the conditioner.

# Detailed Installation Instructions:

(Continued)

4. All electrical connections must be connected according to local codes. The electrical source must be uninterrupted. Install grounding strap on metal pipes.

5. Do not use pipe dope or other types of liquid sealants on any threads. Teflon tape must be used on the drain line  $\frac{3}{4}$ " threads and also on the  $\frac{3}{8}$ " brine-line connections. Note. Factory has pre-teflon taped these fittings.

6. Use caution if soldering inlet, outlet or drain lines. Excess heat will cause damage to the control valve and or bypass valve.

7. A Brine Tank over-flow line of  $\frac{1}{2}$ " ID  $\frac{5}{8}$ " OD is recommended for the brine tank, this line should run from the barb fitting on the side of the tank to an unobstructed drain.

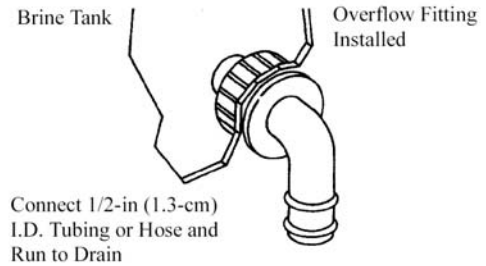

Figure 6

8. Each system comes standard with a high pressure\* injector. It may be necessary to change the injector to match your incoming water pressure.



Figure 7

Injector Selection		
Water Pressure	Injector	Part Number
20 to 60 psi (138 to 414 bar)		AVP-1032980 ( #5 Injector )
61 to 120 psi* (420 to 827 bar)		AVP-1032977 ( #4 Injector )

Table 1

\*Standard Injector (High Pressure)

## System Sizes

Model	Resin Tank Size	Resin Volume	Refill Controller	Backwash Controller	Salt Tank	
					Size	Capacity
SA-TECH PLUS 40 DB	10" x 44"	1.25 ft <sup>3</sup>	.35 gpm	2.8 gpm	15" x 40"	450 lbs
SA-TECH PLUS 48 DB	12" x 48"	1.50 ft <sup>3</sup>	.35 gpm	2.8 gpm	15" x 40"	450 lbs

Table 2

## Start-up Rinsing Procedure:

1. With the plumbing, drain line and over flow connections completed slowly open the water supply allowing the lines to pressurize.

Note the bypass should still be in bypass mode as shown.

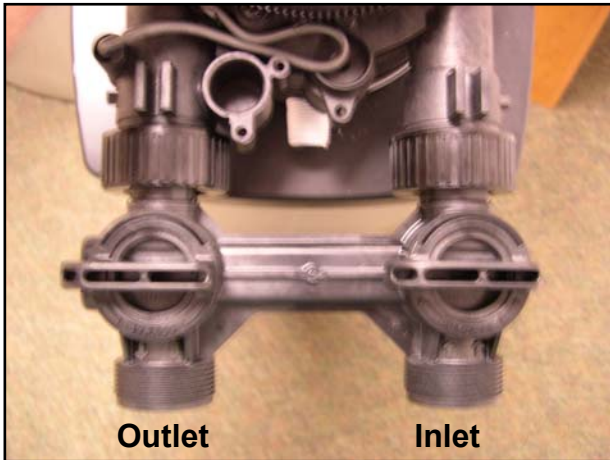

Figure 8

2. With the control valve **unplugged**, manually advance the control valve by depressing the drive gear and rotating the main system gear to the backwash position as shown.

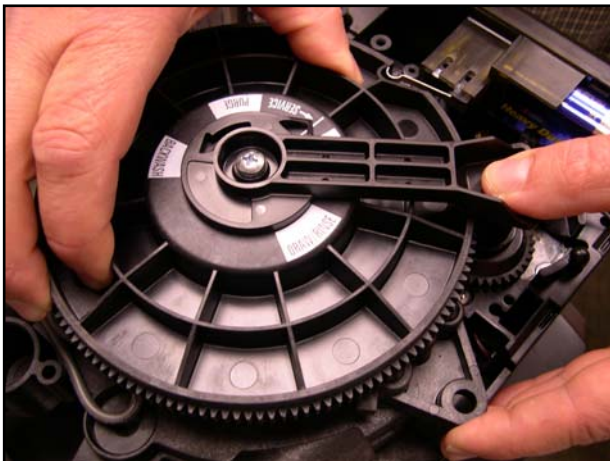

Figure 9

3. Slowly open the inlet valve (only) on the bypass valve allowing the system to pressurize. It is normal to hear air blowing to the drain during this procedure. Once the air clears and water begins to run to the drain, open the inlet valve (only) to the full open position and allow the

water to run to the drain in the backwash for a minimum of 20 minutes.

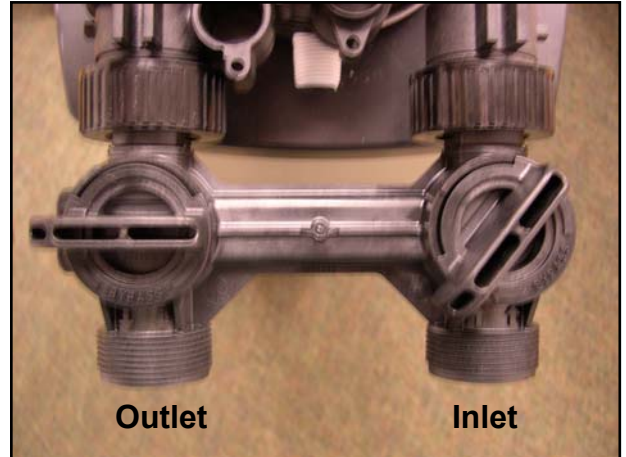

Figure 10

4. After the 20 minute backwash cycle, manually advance the main gear to the purge cycle and allow to run for a minimum of 10 minutes.

**Note:** when advancing the main gear manually while under water pressure it is normal for the gear to encounter resistance as the valve chambers de-pressurize. If resistance occurs allow the valve to de-pressurize by pausing 5 seconds before advancing to the next step.



Figure 11

## Start-up Rinsing Procedure:

(Continued)

6. After the 10 minute purge cycle, manually advance the control valve to the brine refill position for 10 minutes allowing water to flow into the brine storage tank. Once water begins to flow into the tank fill the brine tank with a minimum of 100 lbs of salt pellets.



Figure 12

7. After the 10 minute refill time, manually advance the control valve to the service position.



Figure 13

8. Plug in the control valve.



Figure 14

9. If it is necessary to extend the length of the transformer cord, an optional 15 foot (4.6-m) extension cord is available, P/N AVP-1000907 (See figure 15), or the cord may be spliced as follows:

1. Strip insulation from wire 5/16 inch (7.87 mm) from wire end.
2. Insert stripped wire into barrel of connector and crimp. For best results, crimp twice per wire as shown Figure 16 .

Splice connections or extension wire is not supplied. They are available at hardware or electrical stores.



Figure 15

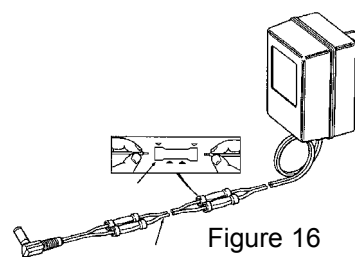

Figure 16

## Battery Back-Up Feature:

The Technetic system is supplied with a battery back-up feature that allows the control to continue monitoring water flow and maintain the proper time of day during short power outages. The control uses a standard 9-volt battery (not supplied).

During a power outage, the display will be turned off and the motor will not run, but the control will continue to monitor water flow. If power is out and a regeneration is needed, the regeneration will be delayed until power is restored. If power is lost during the regeneration, the control will resume the regeneration when power is restored.

A typical new 9-volt alkaline battery will provide approximately two days of power for the control. Older batteries or those exposed to temperature over 75 degrees F (23.9 C) will provide power for a shorter length of time.

The control can be operated without a battery, but the control will not measure water usage or time while the power is off. The control will save all important operating information and programming data during a power outage. No reprogramming is necessary.

Note: It is recommended that the battery be replaced every year or after any extended power outage.



Figure 17

### To install a battery:

1. Complete all installation and standard rinsing procedures.
2. Remove the cover of the Technetic Plus control valve.
3. The battery pocket is located in the upper left corner of the control as shown in figure 17.
4. Insert the battery matching up negative and positive posts

## Programming the Control Valve:

You are now ready to continue programming the control. Programming can be done in both Level I and Level II. Accompanying tables are included for selecting the correct settings for each level. Refer to table guide section on pages 16-17 for sizing options.

**Note:** The system has been pre-programmed with default settings based on model number and ultra high efficiency settings at a water hardness of 15 grains per gallon. While the system may operate with these settings, the following Level I & II settings may need to be changed to meet the actual operating conditions and achieve maximum system capacity and salt efficiency.

## Level I Programming:

Parameters

- P1** = Time of Day
- P2** = Time of Regeneration
- P3** = Water Hardness (grains per gallon of water)
- P4** = Salt usage per regeneration (lbs.)
- P5** = System Capacity (Killograin)

### Default settings for models:

- SA-TECH PLUS 40DB (40DB)
- SA-TECH PLUS 48DB (48DB)
- (Ultra High efficiency settings)

Setting	Description	40DB	48DB
P1	Time of Day	Set to current time of day	
P2	Time of Regen	2 am	2 am
P3	Water hardness	15	15
*P4	Salt usage	3	4
P5	System Capacity	14.0	18.0

Table 3

\* Default settings are representational of Ultra High efficiency.

**Level I Settings** are identified as those that have an LED indicator on the front panel. The green indicator illuminates next to the name of the active control setting. The home owner has access to all of these settings. Pressing the down (↓) arrow button displays the Level I settings in order. By continuing to press the down arrow (↓) button, the settings start over beginning with the time of day. Pressing the up (↑) arrow button displays the settings in reverse order.

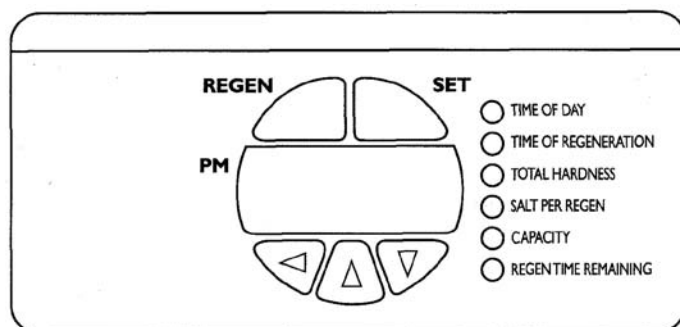

## Level I Programming Parameters:

### P1 = Time of Day AM or PM

Ranges: **1:00 to 12:59** or **00:00 to 23:59**

Minimum increments: **1 Min.**

Units of measure: **Hours & Minutes**

Range: **Depends on the value selected for P13**

### P2 = Time of Regeneration

Ranges: **1:00 to 12:59 AM or PM, 00:00 to 23:59**

Minimum increments: **1 Min.**

Units of measure: **Hours & Minutes**

Range: **Depends on the value selected for P13**

### P3 = Water Hardness Setting

Range: **3 to 250 (grains per gallon) gpg /**

**30 to 2500 (milligrams per liter) mgl**

Minimum increments: **1 for (gpg), 10 for (mgl)**

Units of measure: **Grains per gallon (gpg) /**

**Milligram per liter (mgl)**

Range: **Unit of measure depends on the value selected for P12. Test water hardness (compensated hardness) and enter that value.**

### P4 = Salt Amount (maximum)

Ranges: **0.5 to 99.5 (pounds) or 0.1 to**

**25.5 (kilograms)**

Minimum Increments: **0.5 (pounds) or**

**0.1 (kilograms)**

Units of measure: **Pounds or Kilograms**

Range: **Unit of measure and default depends on value selected for P12. See page 18 for efficiency options and related value.**

### P5 = System Capacity

Ranges: **0.1 to 140 kilograins or 0.01 to**

**14.0 kilograms**

Minimum increments: **0.1 (kilograins) or**

**0.01 (kilograms)**

Units of measure: **Kilograins or Kilograms**

Range: **Unit of measure depends on value selected for P12**

# Level I Programming:

(Continued)

To change the settings press the **SET** button on the far right. The digit of the display starts flashing. If you want to change this number, press the up (↑) arrow button to increase the number or the down (↓) arrow button to decrease the number. To skip the number without changing, press the left (←) arrow button. When you reach the far left digit, pressing the left (←) arrow button will return you to the far right digit.

Note: If you press and hold either the up or down arrow (↑) (↓) button for more than 1 second, the flashing number will increase or decrease at the rate of 10 counts per second.

When the number is correct, press the left arrow button. The far right digit stops flashing and the next digit to the left starts flashing. You can only change the flashing number. Continue changing numbers until you reach the desired setting. Press the SET button. The numbers stop flashing and the control accepts the new setting. After approximately 30 seconds, the control starts alternating the display between Time of Day and Capacity.

Note: If the new setting is not accepted because it was outside the allowable range, the old value will be displayed. Refer to the table guides for the correct settings. (Default settings can be found on Table 6 on page 17.)

### Time of Day

Press the SET button. The display will show the Time of Day with the minutes digit blinking. If you want to change this number, press the up (↑) arrow button to increase the number or the down (↓) arrow button to decrease the number. To skip the number without changing, press the left (←) arrow button. The first number stops flashing and the next number starts flashing. You can only change the flashing number. When you have reached the far left digit, pressing the left (←) arrow button returns you to the far right digit. Continue changing numbers until you reach the desired setting. Press the SET button again to enter the value.

### Time of Regeneration

The next value displayed is the Time of Regeneration, it is similar to Time of Day programming. It has a default setting of 2:00 am. If 2:00 a.m. is acceptable, press the down arrow (↓) button. If this is not acceptable, press the SET button and change the numbers. Press the SET button again to enter the value.

# Level I Programming:

(Continued)

## Water Hardness

The next setting displayed is the Water Hardness in grains per gallon. It is recommended a water test be performed at the time of installation. If multiple water sources are used it will be necessary to change the water hardness settings to match the current water source. The default setting is 15 grains per gallon of water hardness. If this is not acceptable, press the SET button and enter a new value. Any value between 3 and 250 grains per gallon or (30 and 2500 milligrams per liter) is allowed. Press the SET button again to enter the new value.

## Salt Amount

Capacity is the next value displayed and is expressed in Kilograins (kilograms). Refer to page 27 for capacity setting that correspond to the Technetic model and salt efficiency desired.

The pre-set default values for each model are:

Model	Capacity Default	Salt Default
SA-TECHPLUS 40DB	14.0	3 lbs.
SA-TECHPLUS 48DB	18.0	4 lbs.
(Ultra High Efficiency Settings)		Table 4

To change these values, press the SET button and enter a new value. Any value between 0.1 and 140 Kilograins (0.1 and 14.00 kilograms) is allowed.

**Note:** If the calculation for the system capacity exceeds 9999 gallons (99.99 cubic meters) (P5, Capacity, divided by P3, Hardness), the control will display 9999 for capacity until the water usage has dropped the remaining capacity below that number. When water is flowing through the system, the colon in the Time of Day display will blink.

You have now finished Level I programming. The display will alternate between the Time of Day and Capacity if no keys are pressed for 30 seconds. The Capacity value displayed is the volume remaining in gallons (cubic meters for metric) before a regeneration is needed.

# Level II Programming:

The Level II programming has been pre-programmed by the manufacturer to the following settings on Table 6 on page 17. The changing of preset values can be done at this time. Refer to Level II programming parameter in Table 5 on page 16 for options.

**Note:** it is not recommended that homeowners change these values without checking with your local water treatment professional for details. Incorrect programming can cause system malfunction and the possible need for a field service call to re-program the system. System programming is not a warranty item.

To access Level II programming, simultaneously hold down the up (↑) and down (↓) arrows. This will allow you to enter Level II settings P6 thru P19.

## Level II Programming Parameters:

Parameter		Range of Values	Minimum Increments	Units of Measure	Notes
Name	Description				
P6	Refill Controller	1 to 99	1	gpm	.35 gpm, Both Model's
P7	Brine draw value	1 to 99	1	Minutes	15, Both Model's
P8	Not used	N/A	N/A	N/A	N/A
P9	Backwash time	3 to 30	1	Minutes	Skip this parameter to accept the default or enter a value.
P10	Slow Rinse time	8 to 125	1	Minutes	Model: SA-TECH PLUS 40 DB - 67 SA-TECH PLUS 48 DB - 80
P11	Fast Rinse time	2 to 19	1	Minutes	Skip this parameter to accept the default or enter a value.
P12	Units of measure	0 to 1	1		0 = U.S., 1 = metric. Skip this parameter to accept U.S. or enter 1 for metric.
P13	Clock mode	0 to 1	1		0 = 12-hour clock, 1 = 24-hour clock Skip this parameter for a 12-hour clock or enter 1 for a 24-hour clock.
P14	Calendar override	0 to 30	1	Days	0 = no calendar override. Skip this parameter for no calendar override or enter a value.
P15	Reserve type	0 to 3	1	Percent of capacity	0 = variable reserve
P16	Fixed reserve capacity or initial average value	0 to 70	1		Description depends on the value entered for P15. Skip this parameter to accept the default or enter a different value.
P17	Operation type	0 to 1	1		0 = Not used, 1 = 5 cycle counter current, partial salting.
P18	Salt/Capacity change lock out	0 to 1	1		0 = none, 1 = salt/capacity change locked out. Skip this parameter to accept the default or enter 1 to lock out salt/capacity change.
P19	Factory defaults	DO NOT CHANGE	1		Loads in factory default values. <b>Do not change this parameter.</b>

Table 5

## Level I & II Default Settings:

The following table represents pre-set values programmed into the systems at the factory for both Levels I & II for the models shown.

<b>Level I Parameters</b>			
<b>Parameter</b>		<b>Default Settings</b>	
<b>Name</b>	<b>Description</b>	<b>SA-TECH PLUS 40 DB</b>	<b>SA-TECH PLUS 48 DB</b>
P1	Time of Day	Set in field	Set in field
P2	Time of Regen	2:00 AM	2:00 AM
P3	Hardness	Set in field	Set in field
P4	Salt Amount	3 lbs	4 lbs
P5	Capacity	14.0	18.0
<b>Level II Parameters</b>			
<b>Parameter</b>		<b>Default Settings</b>	
<b>Name</b>	<b>Description</b>	<b>SA-TECH PLUS 40 DB</b>	<b>SA-TECH PLUS 48 DB</b>
P6	Refill Controller	.35	.35
P7	Brine draw value	3 lbs. @ 7 min w/ 5 bump injector 7.5 lbs. @ 26 min w/ 4 bump injector 15 lbs. @ 51 min w/ 4 bump injector	4 lbs. @ 9 min. w/ 5 bump injector 9 lbs. @ 31 min. w/ 4 bump injector 18 lbs. @ 61 min. w/ 4 bump injector
P8	Not Used	NA	NA
P9	Backwash time	5	5
P10	Slow rinse time	67	80
P11	Fast rinse time	3	3
P12	Units of measure	0	0
P13	Clock mode	0	0
P14	Calendar override	0	0
P15	Reserve type	0	0
P16	Fixed reserve capacity or initial average value	NA	NA
P17	Operation type	1	1
P18	Salt/Capacity change lock out	0	0
P19	Do not change this parameter	9	9

# System Capacity Inputs:

## System Defaults (Capacity Related)

Level I	Description	SA-TECH PLUS 40 DB	SA-TECH PLUS 48 DB
P3	Water Hardness	15 gpg	15 gpg
*P4	Salt Amount	3 lbs.	4 lbs.
*P5	Capacity	14.0	18.0

Table 2 Options

Lbs of Salt	SA-TECH PLUS 40 DB	SA-TECH PLUS 48 DB
3	14.0	NA
4	16.5	15.5
5	19.0	18.0
6	22.0	21.0
7	24.0	23.5
8	26.0	25.0
9	27.5	26.0
10	29.0	30.0
11	30.0	31.5
12	31.5	33.0
13	32.5	34.0
14	33.5	35.2
15	34.2	36.0
16	35.0	37.0
17	35.7	38.0
18	36.5	39.0
19	37.0	41.0
20	37.8	41.5
21	38.5	42.0
22	39.1	43.0
23	NA	44.0
24	NA	45.2
25	NA	45.9
26	NA	46.5
27	NA	47.2
28	NA	48.0

SA-TECH PLUS 40 DB

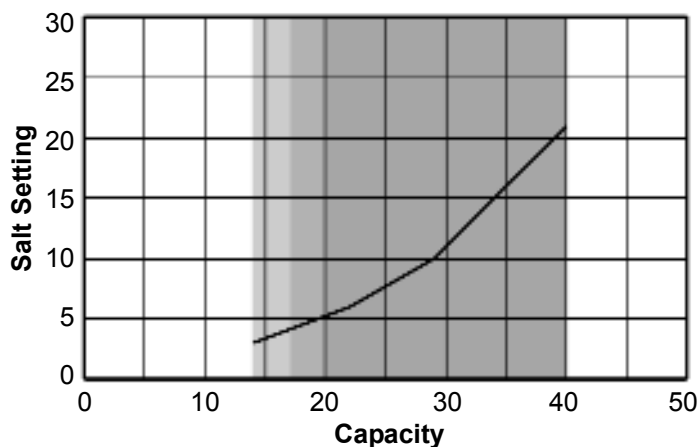

SA-TECH PLUS 48 DB

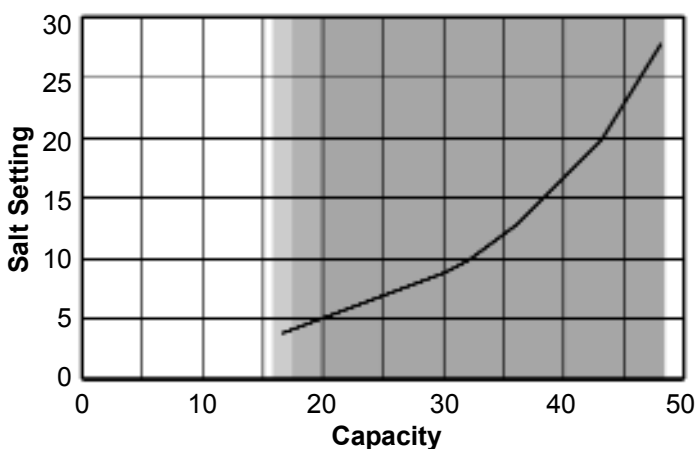

# Flow Diagrams:

**1 Service Position**

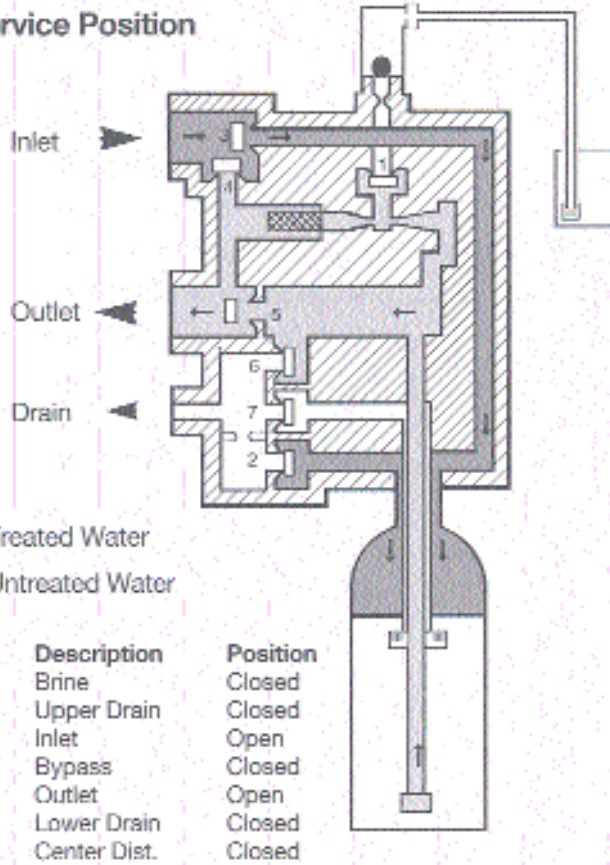

**2 Refill Position**

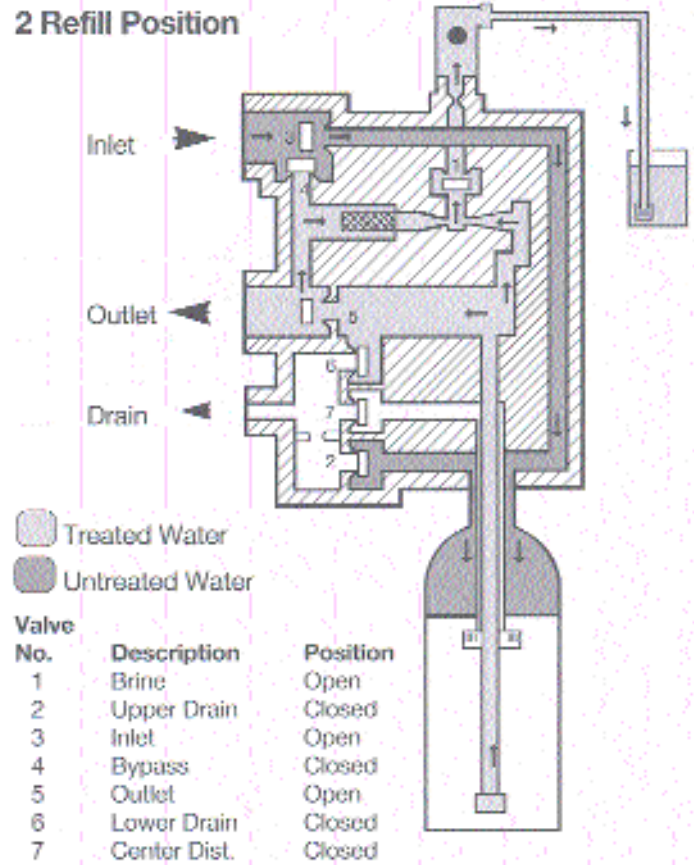

**3 Brine Draw Position**

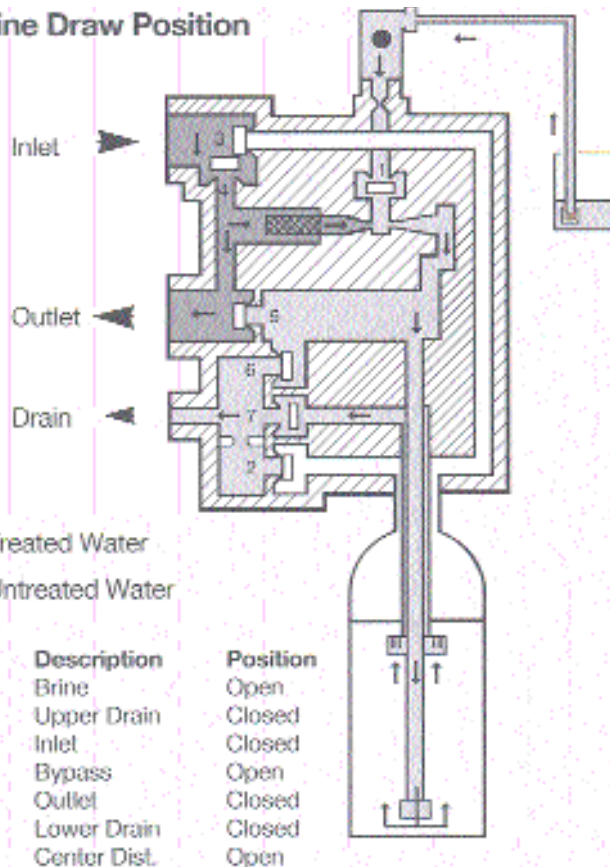

**4 Slow Rinse Position**

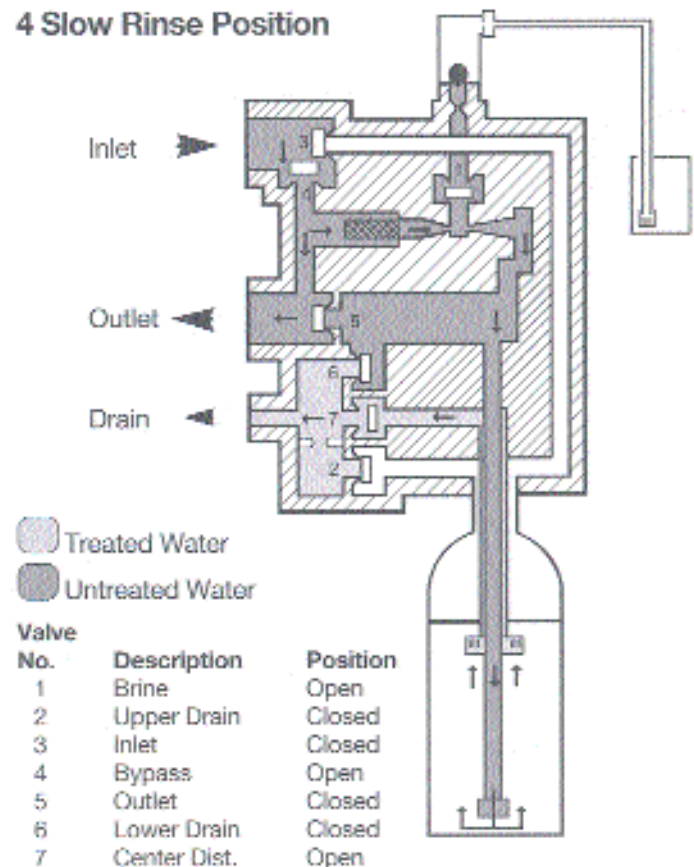

## 5 Backwash Position

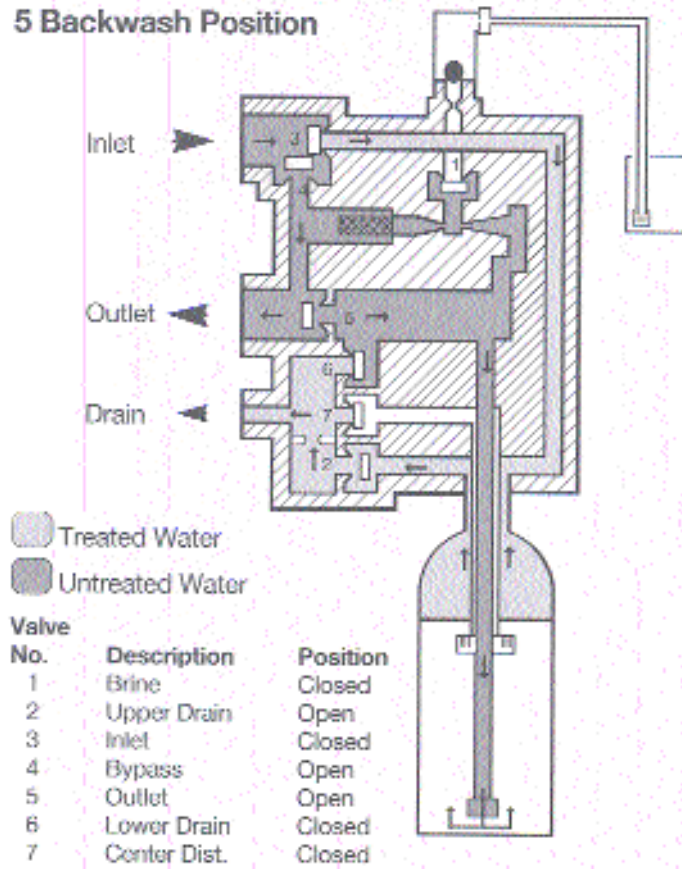

## 6 Fast Rinse Position

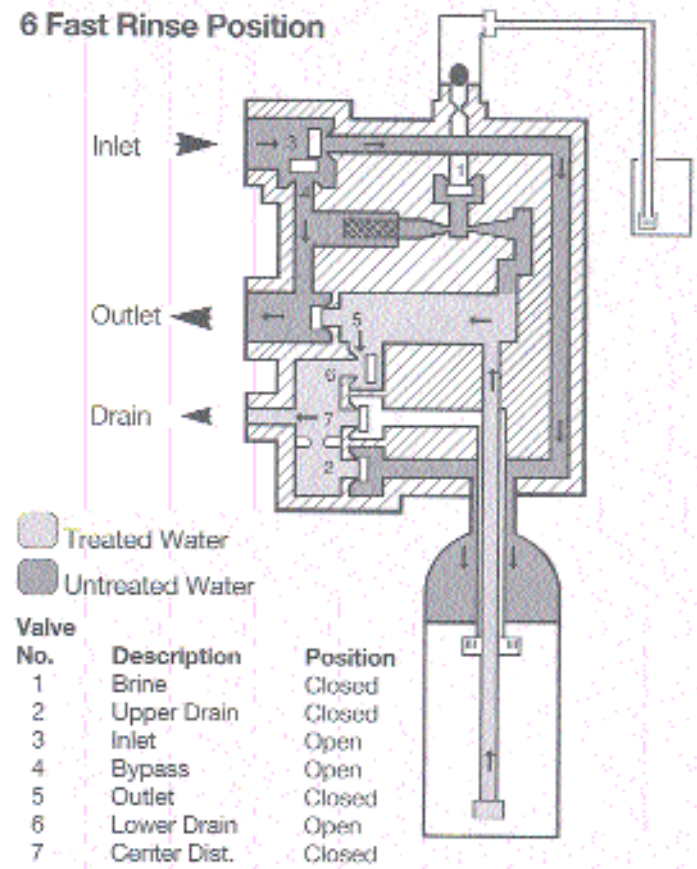

## Valve Disc Identification

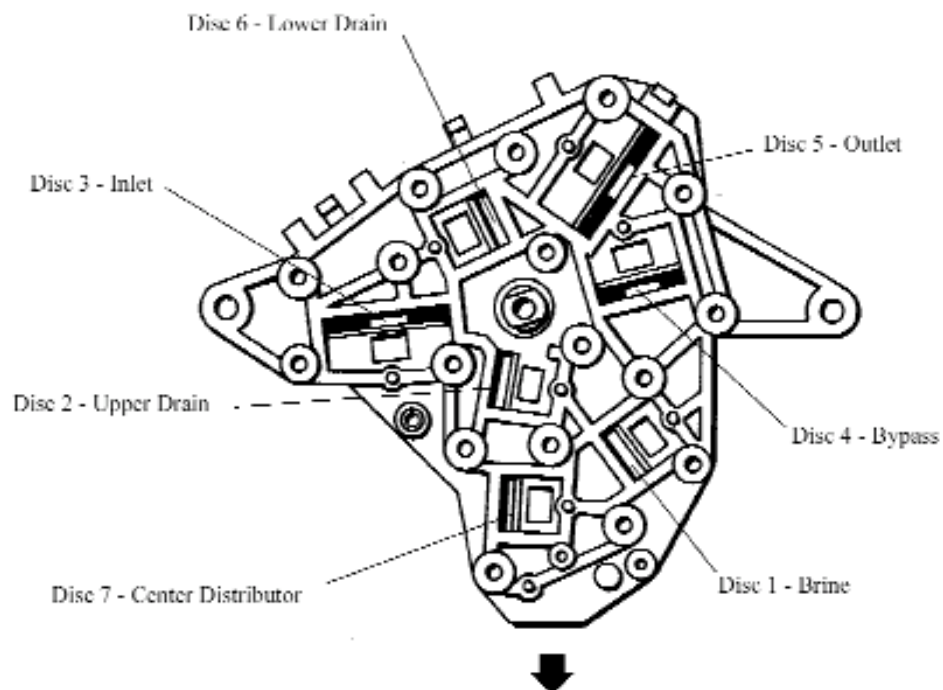

# Troubleshooting:

The control valve may be manually indexed to each regeneration position as follows:

1. Remove the control valve cover.
2. Press down on the top of the drive gear to disengage the cam gear ( Figure 8, Page 9)
3. With the cam gear disengaged, rotate the cam gear counterclockwise to the various positions, using the same steps as described on page 9, Start-up Rinse Procedure.

The control valve may also be operated in a fast mode for testing the control. To activate the fast mode, follow steps 1 and 2 outlined above to disengage the cam gear. When the cam gear is disengaged, it should be advanced slightly in a counterclockwise direction. The switch will then activate the motor to cause the cam gear to advance through all the

cycles in about 30 minutes. The control will not recognize a fast mode as a regeneration. Manual regenerations can be initiated only by pressing the manual regeneration switch on the face of the control.

### Alarms

The Technetic Plus continuously monitors itself and displays an error message if it detects something wrong.

When an error is detected, the display shows the letters “Err” with a number from 1 to 4. The table below lists Err numbers, a description of each error, the cause of the error, and the solutions. To clear the error from the display, press any button on the control. If the error still exists, the control will display the error message again after 30 seconds.

**Technetic Plus Errors**

Indication	Description	Cause	Solution
Err1	Electronics failure.	Control settings need reprogramming.	Press any key to load default values. Err 1 Refer to “Programming the Technetic Plus 1100 Control”.
Err2	Improper start of regeneration (limit switch open when it should be closed).	Valve cam gear has been manually rotated during a regeneration. Valve cam gear has been manually rotated out of Service position. Faulty motor. Faulty motor drive. Faulty switch	Press any key to clear the alarm. (Note: Alarm automatically clears at “TIME OF REGEN”). The control will turn the motor on and drive the cam gear to the proper location. Replace motor assembly. Replace motor assembly. Replace switch.
Err3	Improper finish of regeneration (limit switch closed when it should be open).	Valve cam gear has been manually rotated out of Service position.  Faulty motor. Faulty motor drive. Faulty switch.	The control will turn the motor on and drive the cam gear to the proper location.  Replace motor assembly. Replace motor assembly. Replace switch.
Err4	Improper control settings (one or more settings out of the allowable range).	One or more settings out of the allowable range.	Hardness: Adjust range: 3 to 250. Capacity: Adjust range: 0.1 to 140.0 Refill control: Adjust range per Table 4. Brine Draw Value: Adjust range per Table 4.

## Troubleshooting Procedures

Problem	Possible Cause	Solution
1. Capacity display stays at 9999 even through there is water usage.	a. Total system capacity was calculated to be a value greater than 9999.	a. As the water usage continues, the remaining capacity will drop below 9999 and then other values will be shown.
2. Control does not respond to REGEN button.	a. Button is not active in the programming mode.	a. Refer to the Regeneration section.
3. Control does not display time of day.	a. Transformer unplugged. b. No electric power at outlet. c. Defective transformer. d. Defective circuit board.	a. Connect power. b. Repair outlet or use working outlet. c. Replace transformer. d. Replace control.
4. Control does not display correct time of day.	a. Outlet operated by a switch. b. Power outages.	a. Use outlet not controlled by switch. b. Reset Time of Day and replace battery.
5. Now water flow display when water is flowing (colon does not blink).	a. Bypass valve in bypass position. b. Meter probe disconnected or not fully connected to meter housing. c. Restricted meter turbine rotation due to foreign material in meter. d. Defective meter probe. e. Defective circuit board.	a. Shift bypass valve into service position. b. Fully insert probe into meter housing. c. Remove meter housing, free up turbine and flush with clean water. Turbine should spin freely. If not, refer to the Water Meter Maintenance section. d. Replace control. e. Replace control.
6. Control display is frozen at Regen Time Remaining.	a. Back to back regenerations were requested.	a. Refer to Manual Regeneration section.
7. Control regenerates at the wrong time of day.	a. Power outages. b. Time of day set incorrectly. c. Time of regeneration set incorrectly.	a. Reset time of day to correct time of day and replace battery. b. Reset time of day to correct time of day. c. Reset time of regeneration.
8. Cam Gear stalled in regeneration cycle.	a. Motor not operating. b. Motor runs backwards. c. No electric power at outlet. d. Incorrect voltage or frequency (Hz). e. Broken gear. f. Defective switch. g. Binding of cam gear. h. Water pressure greater than 125 psi during regeneration. i. Defective circuit board.	a. Replace motor assembly. b. Replace motor assembly. c. Repair outlet or use working outlet. d. Replace timer and/or transformer with one of correct voltage and frequency (Hz). e. Replace gear. f. Replace switch. g. Remove foreign object obstruction from valve discs or cam gear. h. Install pressure regulator to reduce pressure. i. Replace control.
9. Continuous regeneration. Cam gear does not stop at the end of regeneration.	a. Defective switch.	a. Replace switch.

**Troubleshooting Procedures**

<b>Problem</b>	<b>Possible Cause</b>	<b>Solution</b>
10. Control does not regenerate automatically or when REGEN button is depressed.	<ul style="list-style-type: none"> <li>a. Transformer unplugged.</li> <li>b. No electric power at outlet.</li> <li>c. Defective motor.</li> <li>d. Defective switch.</li> </ul>	<ul style="list-style-type: none"> <li>a. Connect power.</li> <li>b. Repair outlet or use working outlet.</li> <li>c. Replace motor assembly.</li> <li>d. Replace switch.</li> </ul>
11. Control does not regenerate automatically but does regenerate when REGEN button is depressed.	<ul style="list-style-type: none"> <li>a. If water flow display is not operative, refer to item 5 in this table.</li> <li>b. Incorrect hardness and capacity settings.</li> <li>c. Defective circuit board.</li> </ul>	<ul style="list-style-type: none"> <li>a. Refer to item 5 in this table.</li> <li>b. Set new control values. Refer to the Programming section.</li> <li>c. Replace control.</li> </ul>
12. Run out of soft water between regenerations.	<ul style="list-style-type: none"> <li>a. Improper regeneration.</li> <li>b. Fouled resin bed.</li> <li>c. Incorrect salt setting.</li> <li>d. Incorrect hardness or capacity settings.</li> <li>e. Water hardness has increased.</li> <li>f. Restricted meter turbine rotation due to foreign material in meter housing.</li> <li>g. Water usage below 1/5 gallon per minute.</li> <li>h. Brine draw value from Table 4 is incorrect.</li> <li>i. Incorrect salt type, or use of grid plate (salt shelf).</li> </ul>	<ul style="list-style-type: none"> <li>a. Repeat regeneration making certain that correct salt dosage is used.</li> <li>b. Use resin cleaner.</li> <li>c. Set salt setting to proper level. Refer to the Programming section in this manual.</li> <li>d. Set to correct values. Refer to the Programming section of this manual.</li> <li>e. Set to new value. Refer to the Programming section of this manual.</li> <li>f. Remove meter housing, free up turbine, and flush with clean water. Turbine should spin freely, if not, replace meter.</li> <li>g. Repair leaky plumbing and/or fixtures.</li> <li>h. Set correct brine draw value.</li> <li>i. Do not use block salt or grid plate (salt shelf) in brine tank.</li> </ul>
13. Control does not draw brine	<ul style="list-style-type: none"> <li>a. Low water pressure.</li> <li>b. Restricted drain line.</li> <li>c. Injector or injector screen plugged.</li> <li>d. Injector defective.</li> <li>e. Valve disc 3 and/or 5 not closed.</li> <li>f. Air check valve prematurely closed.</li> </ul>	<ul style="list-style-type: none"> <li>a. Increase water pressure (20 psi at conditioner).</li> <li>b. Remove obstruction.</li> <li>c. Clean injector and screen. Refer to the Cleaning the Injector/Injector Screen section in this manual.</li> <li>d. Replace injector and cap.</li> <li>e. Manually operate cam gear to flush out foreign matter holding disc open. Replace if needed.</li> <li>f. Briefly put control into brine refill status. Refer to the Manual Regeneration section in this manual. Replace or repair air check valve if needed.</li> </ul>
14. Brine tank overflow.	<ul style="list-style-type: none"> <li>a. Brine valve disc 1 held open.</li> <li>b. Valve disc 2 not closed during brine draw, causing brine refill.</li> <li>c. Air leak in brine line to air check.</li> <li>d. Salt setting too high.</li> </ul>	<ul style="list-style-type: none"> <li>a. Manually operate cam gear to flush out foreign matter holding disc open.</li> <li>b. Manually operate cam gear to flush out foreign matter holding disc open.</li> <li>c. Check all connections in brine line for leaks.</li> <li>d. Set in new values. Refer to Programming section in this manual.</li> </ul>

## Troubleshooting Procedures

Problem	Possible Cause	Solution
15. Intermittent or irregular brine draw.	<ul style="list-style-type: none"> <li>a. Low water pressure.</li> <li>b. Defective injector.</li> </ul>	<ul style="list-style-type: none"> <li>a. Increase water pressure (20 psi at conditioner).</li> <li>b. Replace both injector and injector cap.</li> </ul>
16. No conditioned water after regeneration.	<ul style="list-style-type: none"> <li>a. Unit did not regenerate.</li> <li>b. No salt in brine tank.</li> <li>c. Plugged injector.</li> <li>d. Air check valve closed prematurely.</li> <li>e. Incorrect salt type or use of grid plate (salt shelf) in brine tank.</li> </ul>	<ul style="list-style-type: none"> <li>a. Check for power.</li> <li>b. Add salt to brine tank.</li> <li>c. Remove injector and flush it and injector screen.</li> <li>d. Put control momentarily into REFILL to free air check. Replace or repair air check if needed. Refer to instructions.</li> <li>e. Do not use block salt or grid plate (salt shelf) in brine tank.</li> </ul>
17. Control backwashes at excessively low or high rate.	<ul style="list-style-type: none"> <li>a. Incorrect backwash controller.</li> <li>b. Foreign matter affecting controller operation.</li> </ul>	<ul style="list-style-type: none"> <li>a. Replace with correct size controller.</li> <li>b. Remove and clean controller.</li> </ul>
18. Flowing or dripping water at drain line or brine line after regeneration.	<ul style="list-style-type: none"> <li>a. Drain valve (2 or 6) or brine valve (1) held open by foreign matter.</li> <li>b. Weak valve stem return spring on top plate.</li> <li>c. Resin in valve.</li> </ul>	<ul style="list-style-type: none"> <li>a. Manually operate cam gear to flush out foreign matter holding disc open.</li> <li>b. Replace spring.</li> <li>c. Clean valve and backwash control.</li> </ul>
19. Hard water leakage during service.	<ul style="list-style-type: none"> <li>a. Improper regeneration.</li> <li>b. Leaking of bypass valve.</li> <li>c. O-ring around riser tube damaged.</li> <li>d. Incorrect salt type or use of grid plate (salt shelf) in brine tank.</li> </ul>	<ul style="list-style-type: none"> <li>a. Repeat regeneration making sure that the correct salt dosage is used.</li> <li>b. Replace O-ring.</li> <li>c. Replace O-ring.</li> <li>d. Do not use block salt or grid plate (salt shelf) in brine tank.</li> </ul>

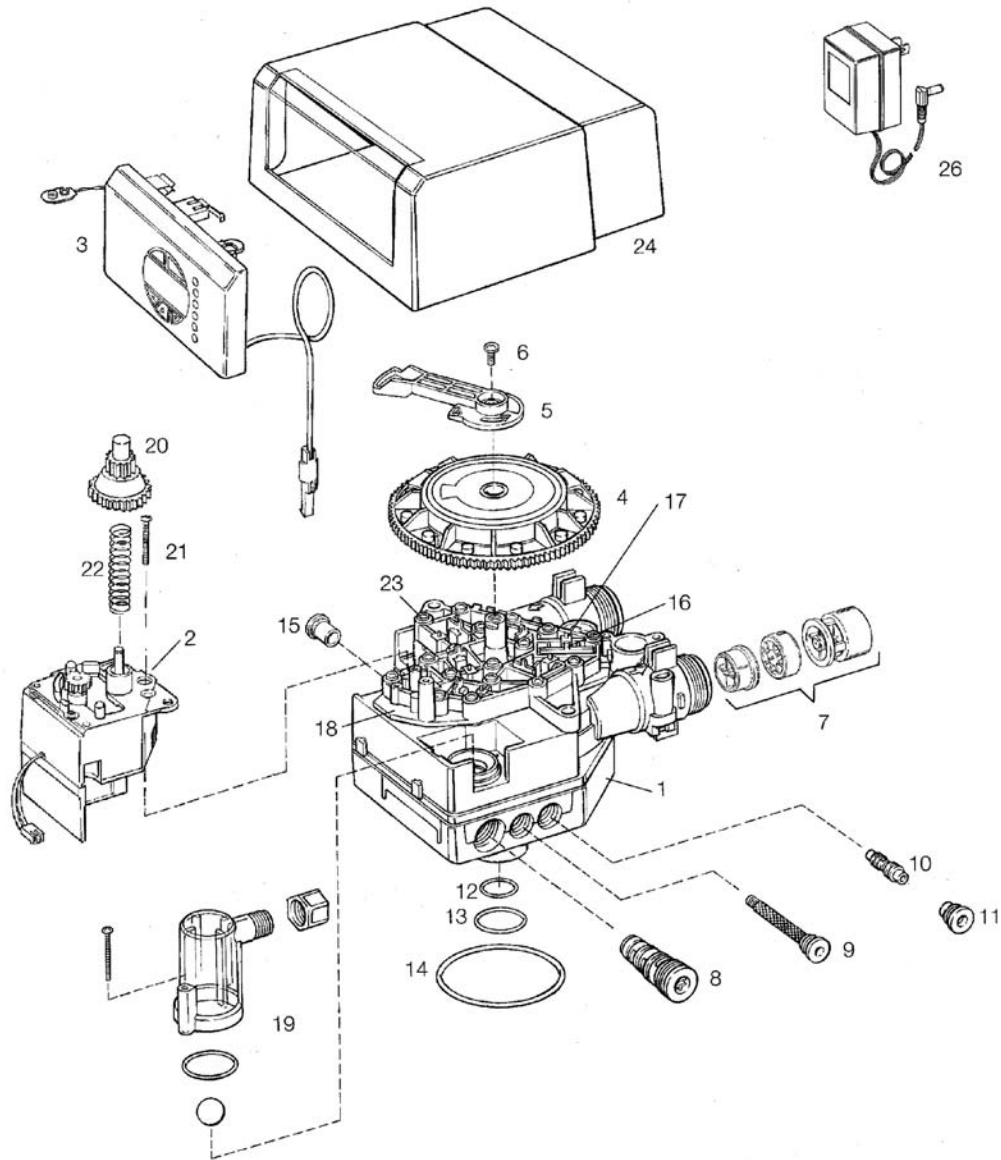

Code	Part No.	Description	Qty.	Code	Part No.	Description	Qty.
1	AVP-1034448	Valve Body Assembly	1	14	AVP-1010429	O-Ring, 3-1/8 ID, 3/16 inch	1
2	AVP-1034347	Motor Drive Assembly, 60 Hz	1	15	AVP-1009056	Cap plug, Black, 1/2 inch	1
	AVP-1034346	Motor Drive Assembly, 50 Hz	1	16	AVP-1040717	Valve Disc Kit	1
3	AVP-1034424	Control Assembly, 1000i	1	17	AVP-1001580	Valve Disc Spring	11
4	AVP-1034362	Cam Gear, 1100 English	1	18	AVP-1034360	Top Plate Assembly with Springs	1
	AVP-1034363	Cam Gear, 1100 Symbols	1	19	AVP-1032416	Air Check Kit	1
5	AVP-1032881	Bracket	1	20	AVP-1032250	Drive Gear	1
6	AVP-1005001	Screw, 10-32 x 1/2 inch	1	21	AVP-1006002	Screw, 8-18 x 1-1/2 inch	2
7	AVP-1033670	Turbine Group	1	22	AVP-1031118	Spring	1
8	AVP-1034340	10-inch Brine/backwash Control	1	23	AVP-1006093	Top Plate Screw	17
9	AVP-1032988	Injector Screen Assembly	1	24	AVP-1033998	Black Cover	1
10	AVP-1032977	Injector Assembly, 4 Bumps	1	25		Not used	
	AVP-1032980	Injector Assembly, 5 Bumps	1	26	AVP-1000811	Transformer, 120V	1
11	AVP-1032985	Injector Cap Assembly	1				
12	AVP-1010140	O-Ring, 1 x 1-1/4 x 1/8 inch	1				
13	AVP-1010129	O-Ring, 1-5/16 x 1-1/2 x 3/32"	1				

# System Diagrams:

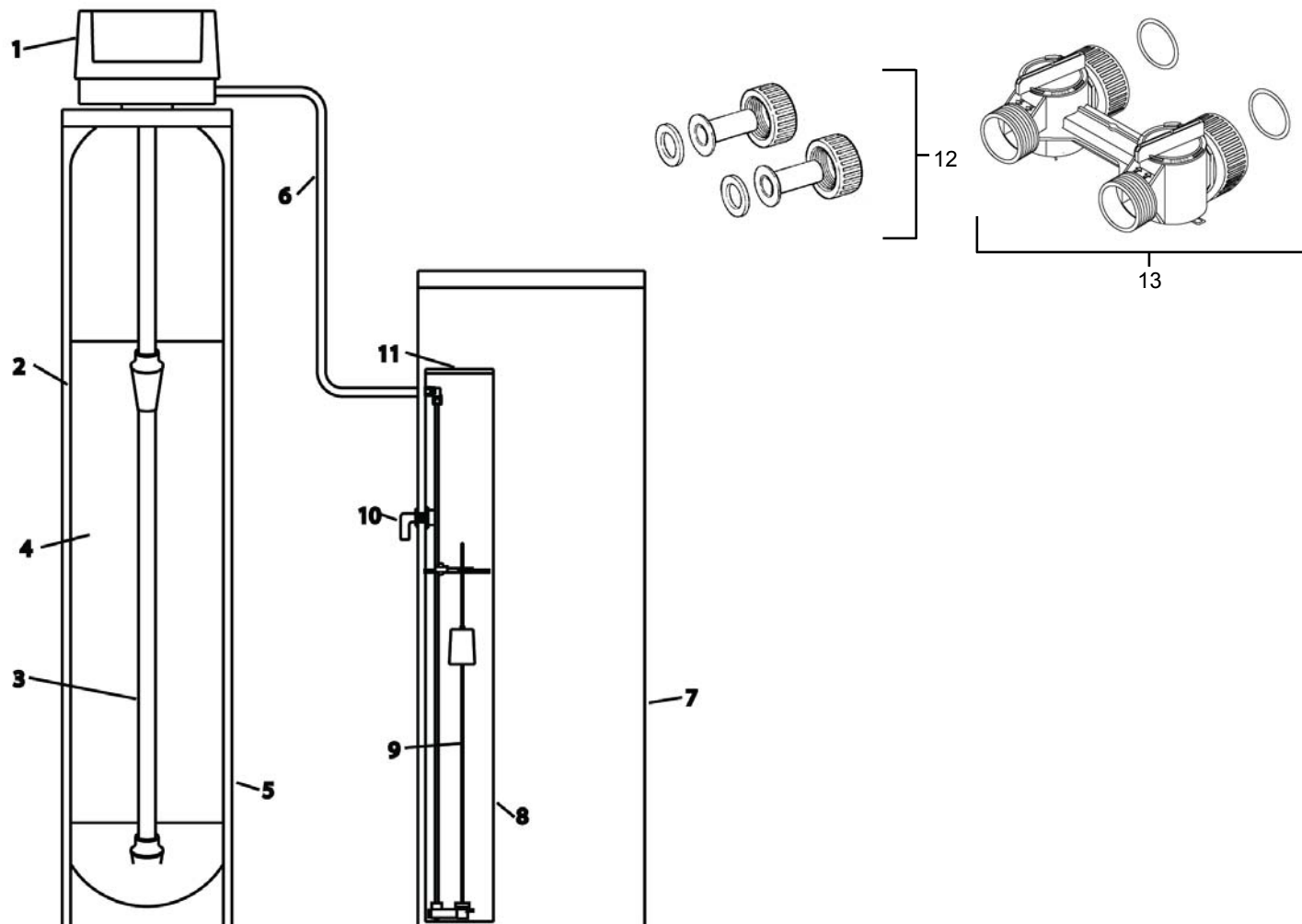

## SA-TECH PLUS 40 DB

## SA-TECH PLUS 48 DB

Code	Part No.	Description	Qty.	Code	Part No.	Description	Qty.
1	AUV-1050643	Technetic Plus Valve	1	1	AUV-1050643	Technetic Plus Valve	1
2	MTK-SP-1044	10x44 Mineral Tank	1	2	MTK-SP-1248	12x48 1248 Mineral Tank	1
3	DST-1080	Tech Distributor, 10x44	1	3	DST-1085	Tech Distributor, 12x48	1
4	MP-TECH 40DB	Resin Media, 1.25 cf	1	4	MP-TECH 48DB	Resin Media, 1.50 cf	1
5	JKT-1325	Mineral Tank Jacket	1	6	TB-1085	Brine Line, 3/8"(per foot)	5
6	TB-1085	Brine Line, 3/8"(per foot)	5	7	BTC-1214	Brine Tank w/ Lid, Technetic	1
7	BTC-1214	Brine Tank w/ Lid, Technetic	1	8	BTC-1093	Brine Well	1
8	BTC-1093	Brine Well	1	9	BTC-1054	Tech Float Assembly	1
9	BTC-1054	Tech Float Assembly	1	10	BTC-1000	Overflow Assembly	1
10	BTC-1000	Overflow Assembly	1	11	BTC-1303	Brine Well Cap	2
11	BTC-1303	Brine Well Cap	2	12	Bypass Tail Kit		1
12	Bypass Tail Kit		1		BP-A-1001606	3/4" Copper Tail Kit	
		BP-A-1001606			BP-A-1001670	1" Copper Tail Kit	
		BP-A-1001670			BP-A-1041210	1 1/4" Copper Tail Kit	
		BP-A-1041210			BP-A-1001613	3/4" CPVC Tail Kit	
		BP-A-1001613			BP-A-1001614	1" CPVC Tail Kit	
		BP-A-1001614		13	BP-A-1040930	Technetic Plus Bypass	1
13	BP-A-1040930	Technetic Plus Bypass	1				

**Notes:**

**Notes:**

